

BHS 135 + DOUBLE CAVITATION 40KHZ
+ LED LASER
+ NEW VMT (VIRTUAL MESO THERAPY)

The BHS135, combines CAVITATION with LASER LED + VMT (virtual mesotherapy) innovative technology developed exclusively by BODY HEALTH that combines electroporation and electrophoresis ensuring the penetration of active substances with spectacular results, allowing absorption of them in depth.



+ DOUBLE CAVITATION WITH LED LASER

The **DOUBLE CAVITATION** therapy with **LASER LED** is doubly effective by using ultrasonic shock waves with barium titanate plates, obtaining a maximum power of 40 Watt effective. For this therapy it's used **2 applicators** and the equipment emits a frequency of **40 kHz**. This machine sculpts the body and gets rid of fat cells in a non invasive, safe and efficient way. Besides, it fights **cellulite, flabbiness, wrinkles, spots, varicose veins and rosacea**. Its pulsating power and the repetitiveness cycles generate an ultrasonic intensity on the tissue without affecting the surrounding tissues. It **generates small micro bubbles** by changes in partial pressures causing them to implode breaking down the fat cells in localized areas, turning them into a liquid substance, which is eliminated through the lymphatic system and urinary tract.



+ VMT FACIAL AND CORPORAL

Body Health has developed **VMT (ELECTROPORATION + ELECTROPHORESIS)** an exclusive therapy which includes the most complete range of products to treat corporal and facial disorders. It has applicators that facilitate the penetration of the product with two carefully studied measures for better implementation and adaptation for different **facial contours and body** as well. Consists in the transdermal administration of active substances by the action of an electric current or **electromagnetic waves** with short high voltage pulses. Such current allows the passage of substances since it increases the permeability of the cellular membrane and alters the structure of the phospholipid bilayer.

BHS 135 ACCESORIES

*Aluminum



CAVITATION APPLICATORS WITH LED LASER



CONNECTORS



* FACIAL AND CORPORAL APPLICATORS



VMT PRODUCTS

VMT PRODUCTS:

- TIGHTENING VMT • ANTI-WRINKLE VMT • WHITENING VMT
- ANTI-CELLULITE VMT • VMT OF THE BLOOD VESSELS

APPLICATIONS

CORPORAL

- CELLULITE
- LOCALIZED ADIPOSITA
- FLABBINESS
- BLOOD VESSELS
- HYPERPIGMENTATIONS

FACIAL

- WRINKLES
- FLABBINESS
- HYPERPIGMENTATIONS
- BLOOD VESSELS



BEFORE AFTER



BEFORE AFTER



BH H&S
BODY HEALTH HELP & SUPPORT

- TREATMENT TRAINING
- TECHNICAL TRAINING
- MARKETING TOOLS
- MEDICAL PROTOCOLS

We consider our clients our strategic business members.

They receive our knowledge and professional support every time. This is why we offered with each purchase: Treatment Training, Technical Training, Medical protocols regarding each Body Health Treatment and Marketing Tools to satisfy whatever our clients need, so that they can do better business with their Body Health equipment.

CHARACTERISTICS

- Easy to use software
- Keyboard with posterior luminosity
- Power variability during the application
- A continuous insulation system, which avoids electric shocks and burns; thus, it is safe for the patient
- High quality surgical stainless steel applicators.

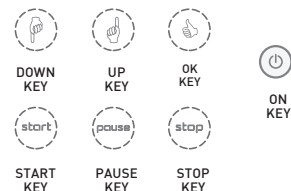
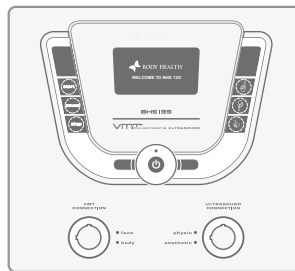

THERAPIES

DOUBLE CAVITATION:

40 KHZ

MAXIMUM POWER CONSUMPTION

40 WATT

DERMOPORATION:

WAVE SHAPE OWNED BY
BODY HEALTH.

POWER CONSUMPTION

23 WATT

DERMOLEDS:

COLOUR

RED

WAVE LENGTH

660 NM

INCIDENCE ANGLE

30°

POWER

100 MW

LIGHT POWER

1600 TO 2000 MCD

IMAX

20 MA

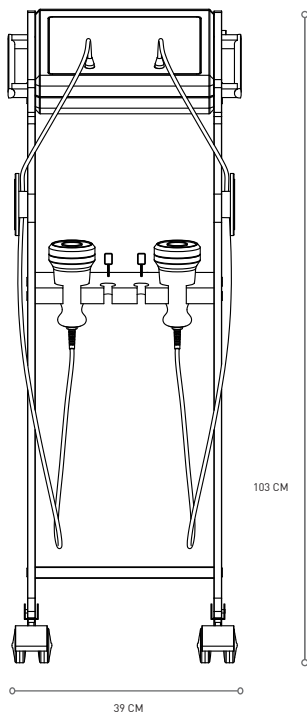
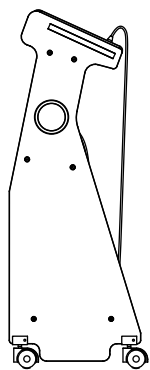

TECHNICAL INFORMATION

BHS 135

COUNTRY	ARGENTINA
MANUFACTURER	BODY HEALTH GROUP
NAME OF PRODUCT	BHS 135
CLASS	CLASS ONE
WIDTH	39 CM
LENGTH	38 CM
HEIGHT	103 CM (WITH TABLE)
WEIGHT	15 KG. (WITH TABLE)
CERTIFIED BY	CE, FCC, ISO 9001, ISO 13486

POWER CONSUMPTION	35 WATT
MAXIMUM FREQUENCY	50 KHZ
FUSES	1,5 AMP
POWER	00 - 99%
ELECTRONICS	CONTROLLED BY MICROPROCESSOR
TEMPERATURE	0°C TO 50°C
HUMIDITY	80% MAX
TIMER	00 - 99 MINUTES